

What **benefits** do UniQa He offer on the environment side?

100% free of polluting gas emissions (CO2 and NOx) and noise otherwise caused by endothermic traction or auxiliary engines, UniQa He is the first professional spreader that can meet Kyoto Protocol values and respect our cities and rural areas.

100% Sustainable, the first completely sustainable professional salt spreader on the market today; we have endeavoured to create equipment that respects the environment, avoids the waste of natural resources and reduces emissions without compromises on the performance side.

99% recyclable; zero environmental impact through recycling and reusing materials. Less than 1% is not recyclable but is reusable.

100% eco-friendly, through the complete elimination of hydraulic filters, hoses, or oil disposal; there are no pollutants to dispose of during the entire life cycle of the unit.

75% more efficient energy consumption, compared to the traditional hydraulic systems.

UniQa He is a sustainable solution ready today, representing our commitment to build a better future for our children.

Bucher Municipal

Giletta SpA
Via A. De Gasperi, 1
I-12036 Revello (CN)
tel. +39 0175 258 800
info.it@buchermunicipal.com
www.buchermunicipal.it

At Bucher Municipal we design innovative solutions for cleaning and winter maintenance and help our customers to grow and make their work more efficient and profitable. With over 200 years in the business, we are committed to helping you accomplish more with less. We are proud to be considered a reliable partner and work at local level with you to create a smarter, cleaner and more efficient future.



● Bucher Municipal locations
● Distribution Partners

BMU_5p_UniQa_He_ENG_rev00 - 07/2023
The technical data and pictures are indicative and not binding.



Driven by better

BUCHER
municipal

UniQa He

The 100% electric chain spreader





Chain extraction system

The system consists of a metal conveyor belt of increased width made of steel, with high-strength crossbars. The metal belt is driven by solid pinion shaft that provide constant traction while maintaining proper synchrony in the feed, free from skidding.

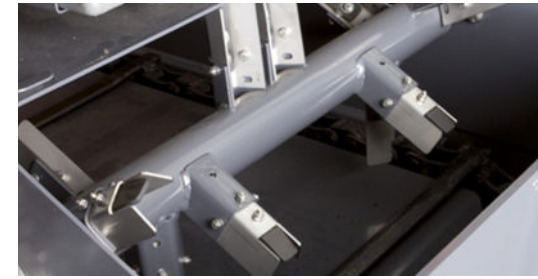

Roller breaker

Placed transversely at the end of the chain conveyor system. Allows a homogeneous and continuous inflow of material to the spreading disc and breaks all lumps carried by the wide conveyor system into small pieces. Breaker blade constructed of stainless steel and polyethylene.



Humidification system and side tanks

Humidification system with polyethylene side tanks and volumetric pump with maintenance-free nitrile impeller. Innovative system that ensures perfect homogeneity in salt humidification. This system improves spreading and increases the effectiveness of the material spread to the benefit of economic savings.



Screening grids

The screen grids are made of galvanized steel and prevent oversized material from entering the hopper. The meshes that make them up have a size of 80x80 mm.

	HP340e	HP350e	HP360e	HP370e	
Hopper capacity	4	5	6	7	m ³
Capacity of solution tanks	2270	2270	2270	2270	l
Min/max spreading width	2 + 12	2 + 12	2 + 12	2 + 12	m
Salt dispensing capacity	0 + 40	0 + 40	0 + 40	0 + 40	g/m ²
Gravel dispensing capacity	0 + 350	0 + 350	0 + 350	0 + 350	g/m ²
Load length	3600	3600	3600	3600	mm

	HP450e	HP460e	HP470e	HP490e	HP4110e	
Hopper capacity	5	6	7,5	9	11	m ³
Capacity of solution tanks	2600 / 3000	2600 / 3000	2600 / 3000	2600 / 3000	2600 / 3000	l
Min/max spreading width	2 + 12	2 + 12	2 + 12	2 + 12	2 + 12	m
Salt dispensing capacity	0 + 40	0 + 40	0 + 40	0 + 40	0 + 40	g/m ²
Gravel dispensing capacity	0 + 350	0 + 350	0 + 350	0 + 350	0 + 350	g/m ²
Load length	4400	4400	4400	4400	4400	mm

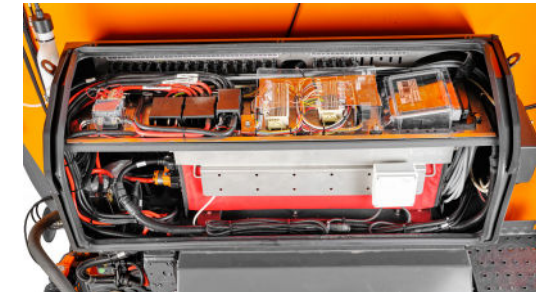

Electrical system

The electrical system, thanks to the new layout, facilitates any repair work. Through remote control, it is possible to know which equipment needs maintenance, turning unplanned shutdowns into shorter maintenance times and thus increasing service availability.



Motor assembly

The electric motor with built-in inverter enables precise tuning, remarkable power and high efficiency. Compact design prevents leakage or interference making it suitable for use in any field. IP67 ingress protection rating certified by motor assembly and inverter.

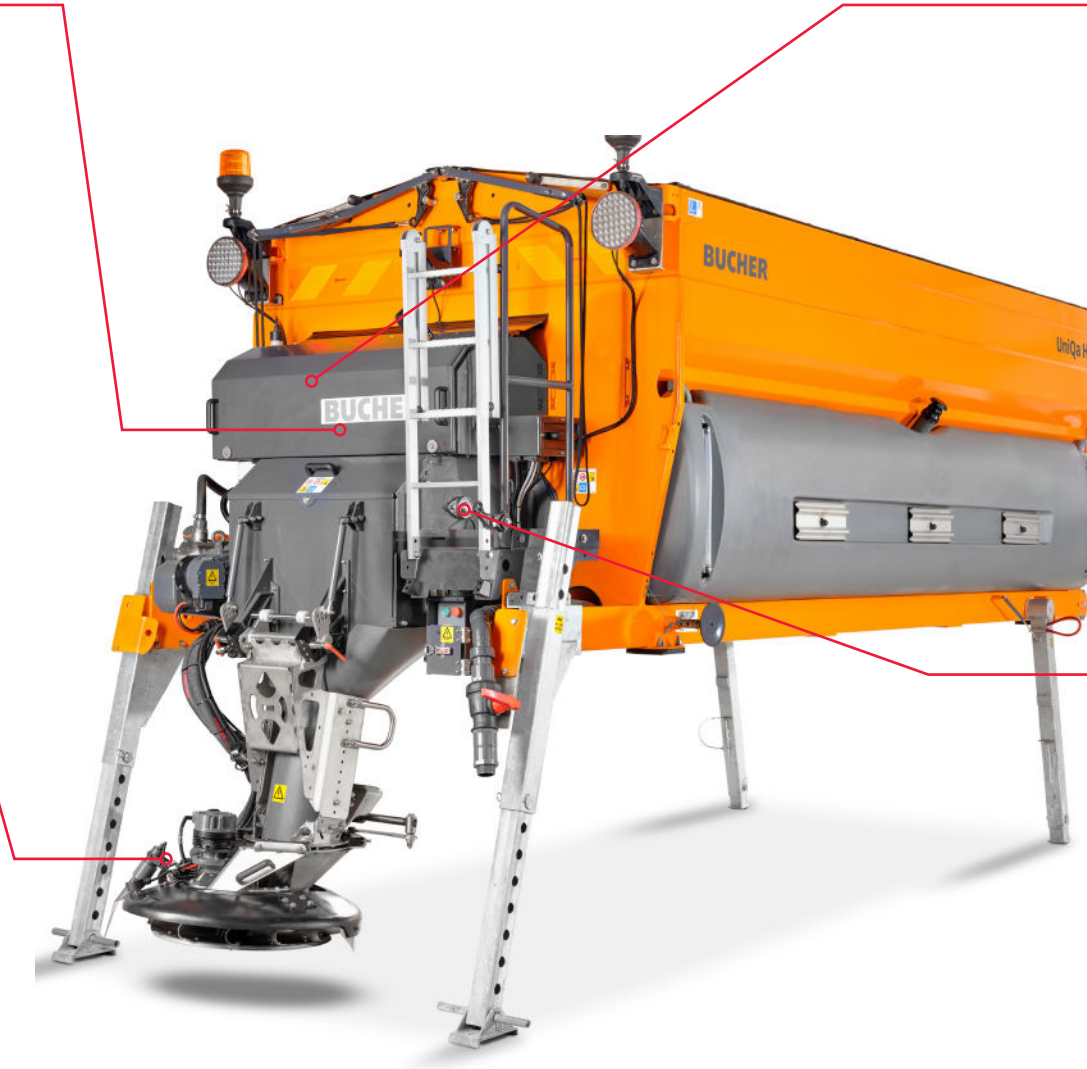

Battery

Maintenance-free latest generation lithium battery, which enables partial and fast charging cycle without damage and designed for more than 8000 hours of work. Battery management system with intelligent technology enabling real-time remote diagnosis, automatic temperature protection, automatic cell voltage balancing. Low voltage 48v electrical system enables easy and safe service.



Control panel: EcoSat Pro

7-inch touch screen control panel, 12V or 24V power supply, RFID sensor for user identification, significantly improved performance and speed compared to Ecosat 10. There are also physical buttons on the device that work symbiotically with the touch screen as well as 3 encoders for manual spreading adjustment. It provides online access to navigation and is easily integrated with the Bucher Assist system.



Bucher ASSIST

ASSIST enables cost-effective, flexible and efficient winter services thanks to its innovative tools for the service responsible as well as for the driver. ASSIST reduce the operator workload while allowing him to comply with operational procedures, due to the man-machine collaboration, improving the winter road maintenance quality.

Online management

Accessible from everywhere, using a simple internet connection; all the tools used for winter services management are available through a single web portal. Real-time weather analysis, telemetric and road morphology studies offer to the service responsible all necessary data to create precise winter maintenance mission, anytime and anywhere with the guarantee to carry out the exact planned procedure.

Spreading automation

Winter maintenance operators are helped by an automated system, able to adjust autonomously each spreading parameter; this means that the equipment always applies the exact dosage with the right pattern. The on-board unit includes an accurate GPS navigation system able to guide the operator with visual and vocal messages. Automated spreading combined with satellite navigation, results in economic use of de-icing materials, the best winter maintenance operations with any level of driver skills while reducing their workload.

Cloud connection

The cloud connection makes possible real-time data sending and collecting both for on-board unit and the web portal; this enables features like live tracking, mission modification or data analysis from remote. Moreover it helps the user, or directly the Bucher Municipal service, to determinate the condition of in-service equipments in order to predict when maintenance should be performed, avoiding unplanned stops.